

**SINGLE-STAGE, MULTI-SPEED
GAS FURNACES**
80% AFUE
HEATING INPUT: 40,000 – 140,000 BTU/H



■ Contents

Nomenclature.....	2
Product Specifications.....	3
Dimensions	5
Airflow Data	8
Wiring Diagram.....	10
Accessories	11
Minimum Filter Sizes	11

■ Standard Features

- Heavy-duty stainless-steel, dual-diameter tubular heat exchanger
- Single-stage gas valve
- Durable Hot-surface igniter
- Quiet, single-speed draft inducer
- Self-diagnostic control board
- Color-coded low-voltage terminals
- Multi-speed blower motor
- California Low NO_x emissions models available
- Can no longer be installed in California's South Coast Air Quality Management District (SCAQMD) on or after October 1, 2019.
- AHRI Certified; ETL Listed

■ Cabinet Features

- Multi-position installation:
DM80SS: upflow, horizontal left or right
DD80SS: dedicated downflow
- Convenient left or right connection for gas and electrical service
- Cabinet air leakage (Q_{Leak}) ≤ 2%
- Heavy-gauge steel cabinet with durable baked-enamel finish
- Foil faced insulated heat exchanger



* Complete warranty details available from your local dealer or at www.daikincomfort.com. To receive the Lifetime Heat Exchange Limited Warranty and the 12-Year Parts Limited Warranty, online registration must be completed within 60 days of installation. Additional requirements for annual maintenance are required for the Unit Replacement Limited Warranty. Online registration and some of the additional requirements are not required in California or Quebec.

	D	M	80	S	S	060	3	A	X	*	*	
	1	2	3,4	5	6	7,8,9	10	11	12	13	14	
Brand												Minor Revision
D - Daikin Brand												A - Initial Release B - 1st Revision
Configuration												Major Revision
M - Upflow/Horizontal C - Downflow/Horizontal D - Dedicated Downflow												A - Initial Release B - 1st Revision
AFUE												NOx
97 - 97-98% AFUE 96 - 96% AFUE	92 - 92% AFUE 80 - 80% AFUE											N - Natural Gas X - Low NOx
Gas Valve												Cabinet Width
M - Modulating V - Two Stage	H - Convertible Two-Stage S - Single Stage											A - 14" C - 21" B - 17½" D - 24½"
Motor												Maximum CFM
C - Variable Speed ECM / Communicating E - Multi-Speed ECM	S - Multi-Speed PSC											2 - 800 CFM 3 - 1200 CFM 4 - 1600 CFM 5 - 2000 CFM
MBTU/h												
040 - 40,000 BTU/h 060 - 60,000 BTU/h 080 - 80,000 BTU/h	100 - 100,000 BTU/h 120 - 120,000 BTU/h 140 - 420,000 BTU/h											

	DM80SS 0403A*A	DM80SS 0603A*A	DM80SS 0604B*A	DM80SS 0804B*A	DM80SS 0805C*A	DM80SS 1005C*A	DM80SS 1205D*A	DM80SS 1405D*A
HEATING CAPACITY								
Input ¹	40,000	60,000	60,000	80,000	80,000	100,000	120,000	140,000
Natural Gas Output ¹	32,000	48,000	48,000	64,000	64,000	80,000	96,000	112,000
LP Gas Output ¹	32,000	48,000	48,000	64,000	64,000	80,000	96,000	96,000
AFUE ²	80	80	80	80	80	80	80	80
Available AC @ 0.5" ESP	3	3	4	4	5	5	5	5
Temperature Rise Range (°F)	25 - 55	20 - 50	20 - 50	35 - 65	35 - 65	35 - 65	40 - 70	40 - 70
CIRCULATOR BLOWER								
Size (D x W)	10" x 6"	10" x 6"	10" x 8"	10" x 8"	10" x 10"	10" x 10"	11" x 10"	11" x 10"
Horsepower @1075 RPM	⅓	⅓	½	½	½	½	¾	¾
No. of Speeds	4	4	4	4	4	4	4	4
Vent Diameter ³	4"	4"	4"	4"	4"	4"	4"	4"
No. of Burners	2	3	3	4	4	5	6	6
ELECTRICAL DATA								
Min. Circuit Ampacity ⁴	4.8	4.8	8.8	8.8	8.8	8.8	8.8	14.7
Max. Overcurrent Device (amps) ⁵	15	15	15	15	15	15	15	15
SHIP WEIGHT (LBS)								
	84	88	98	106	114	118	130	130

¹ Natural Gas BTU/h; for altitudes above from 0' to 5,500' above sea level, reduce input rating 4% for each 1,000' above 5,500' altitude.

² DOE AFUE based upon Isolated Combustion System (ICS)

³ Vent and combustion air diameters may vary depending upon vent length. Refer to the latest editions of the National Fuel Gas Code NFPA 54/ANSI Z223.1 (in the USA) and the Canada National Standard of Canada, CAN/CSA B149.1 and CAN/CSA B142.2 (in Canada).

⁴ Minimum Circuit Ampacity = (1.25 x Circulator Blower Amps) + ID Blower amps. Wire size should be determined in accordance with National Electrical Codes. Extensive wire runs will require larger wire sizes.

⁵ Maximum Overcurrent Protection Device refers to maximum recommended fuse or circuit breaker size. May use fuses or HACR-type circuit breakers of the same size as noted.

NOTES

- All furnaces are manufactured for use on 115 VAC, 60 Hz, single-phase electrical supply.
- Gas Service Connection ½" FPT
- Important: Size fuses and wires properly and make electrical connections in accordance with the National Electrical Code and/or all existing local codes.

	DD80SS 0403A*A	DD80SS 0603A*A	DD80SS 0804B*A	DD80SS 1005C*A
HEATING CAPACITY				
Input ¹	40,000	60,000	80,000	100,000
Natural Gas Output	32,000	48,000	64,000	80,000
LP Gas Output	32,000	48,000	64,000	80,000
AFUE ²	80	80	80	80
Available AC @ 0.5" ESP	3	3	4	5
Temperature Rise Range (°F)	25 - 55	30-60	35-65	40 - 70
CIRCULATOR BLOWER				
Size (D x W)	10" x 6"	10" x 6"	10" x 8"	10" x 10"
Horsepower @1075 RPM	1/3	1/3	1/2	3/4
No. of Speeds	4	4	4	4
Vent Diameter ³	4"	4"	4"	4"
No. of Burners	2	3	4	5
ELECTRICAL DATA				
Min. Circuit Ampacity ⁴	4.8	4.8	8.8	10.5
Max. Overcurrent Device (amps) ⁵	15	15	15	15
SHIP WEIGHT (LBS)				
	88	92	105	113

¹ Natural Gas BTU/h; for altitudes above from 0' to 5,500' above sea level, reduce input rating 4% for each 1,000' above 5,500' altitude.

² DOE AFUE based upon Isolated Combustion System (ICS)

³ Vent and combustion air diameters may vary depending upon vent length. Refer to the latest editions of the National Fuel Gas Code NFPA 54/ANSI Z223.1 (in the USA) and the Canada National Standard of Canada, CAN/CSA B149.1 and CAN/CSA B142.2 (in Canada).

⁴ Minimum Circuit Ampacity = (1.25 x Circulator Blower Amps) + ID Blower amps. Wire size should be determined in accordance with National Electrical Codes. Extensive wire runs will require larger wire sizes.

⁵ Maximum Overcurrent Protection Device refers to maximum recommended fuse or circuit breaker size. May use fuses or HACR-type circuit breakers of the same size as noted.

NOTES

- All furnaces are manufactured for use on 115 VAC, 60 Hz, single-phase electrical supply.
- Gas Service Connection ½" FPT
- Important: Size fuses and wires properly and make electrical connections in accordance with the National Electrical Code and/or all existing local codes.

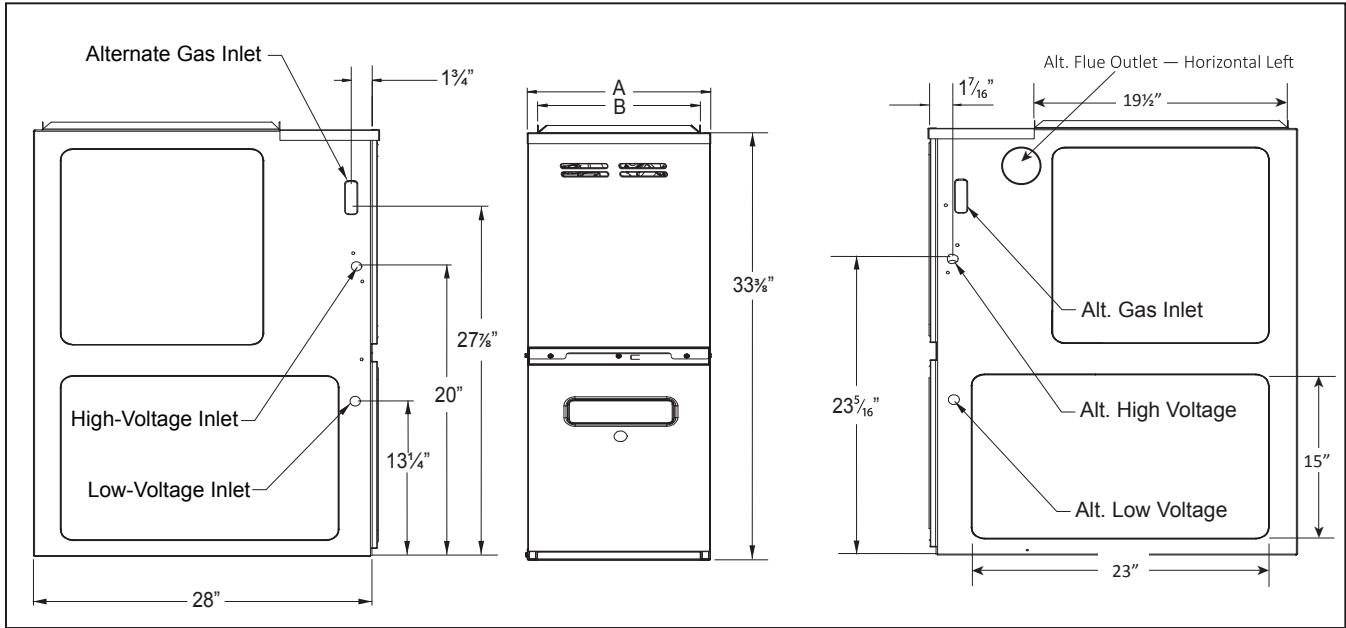

MODEL	A	B
DM80SS0403A*A	14"	12 1/2"
DM80SS0603A*A	14"	12 1/2"
DM80SS0604B*A	17 1/2"	16"
DM80SS0804B*A	17 1/2"	16"

MODEL	A	B
DM80SS0805C*A	21"	19 1/2"
DM80SS1005C*A	21"	19 1/2"
DM80SS1205D*A	24 1/2"	23"
DM80SS1405D*A	24 1/2"	23"

NOTES

- Line voltage wiring can enter through the right or left side of furnace. Low-voltage wiring can enter through the right or left side of furnace.
- Conversion kits for high-altitude (5500+ ft) natural gas operation are available.
- Installer must supply the following gas line fittings, according to which entrance is used:
 Left: One 90° street elbow; one 2 1/2" pipe nipple; one 90° elbow; straight pipe; one ground joint union
 Right: Straight pipe to reach gas valve

MINIMUM CLEARANCES TO COMBUSTIBLE MATERIALS

SIDES	REAR	FRONT	BOTTOM	VENT		TOP
				SW	B	
1"	0"	3"	C	6"	1"	1"

C = If placed on combustible floor, the floor MUST be wood ONLY.

NOTES

- For servicing or cleaning, a 24" front clearance is recommended.
- Unit connections (electrical, flue, and drain) may necessitate greater clearances than the minimum clearances listed above.
- In all cases, accessibility clearance must take precedence over clearances from the enclosure where accessibility clearances are greater.
- Refer to the appropriate USA and Canadian codes:
 - In the USA: the National Fuel Gas Code NFPA 54 / ANSI Z223.1
 - In Canada: the Canada National Standard of Canada, CAN/CSA B149.1 and CAN/CSA B142.2

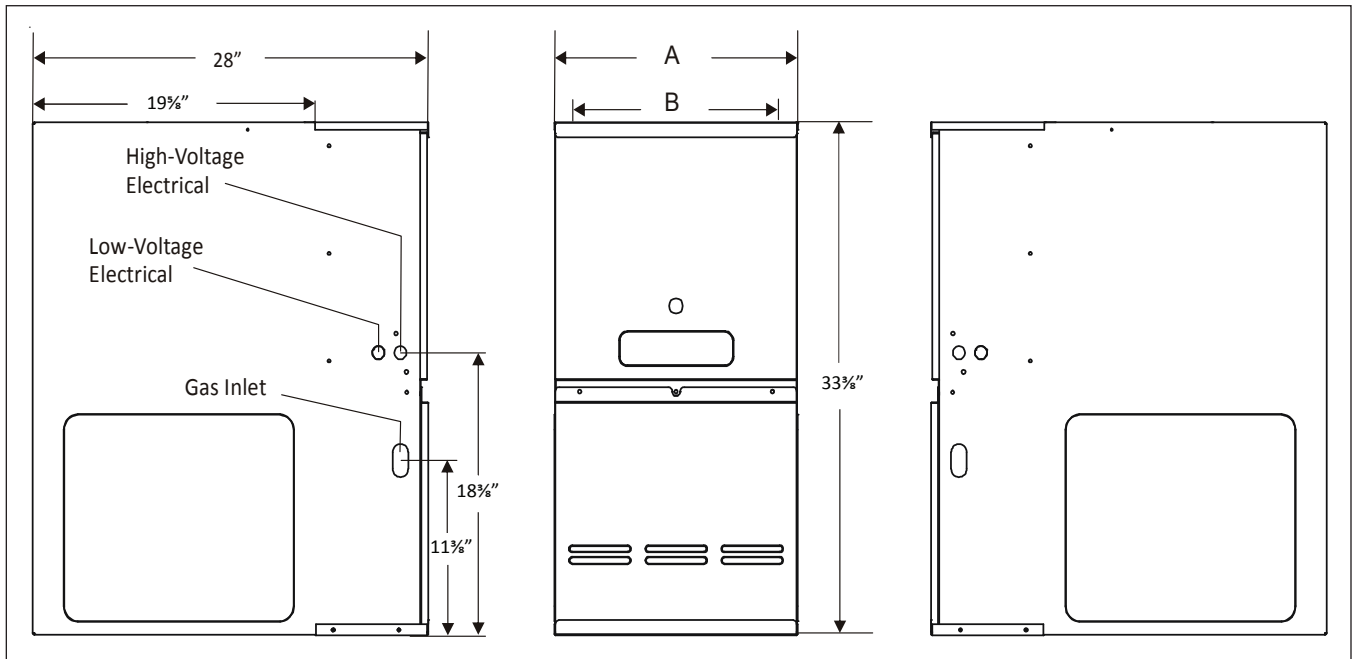

MODEL	A	B
DD80SS0403A*A	14"	12 1/2"
DD80SS0603A*A	14"	12 1/2"
DD80SS0804B*A	17 1/2"	16"
DD80SS1005C*A	21"	19 1/2"

NOTES

- Line-voltage wiring can enter through the right or left side of furnace.
- Low-voltage wiring can enter through the right or left side of furnace.

MINIMUM CLEARANCES TO COMBUSTIBLE MATERIALS

SIDES	REAR	FRONT ¹	VENT ²		TOP
			SW	B	
1"	0"	3"	6"	1"	1"

¹ 24" clearance for serviceability recommended.

² Single Wall Vent (SW) to be used only as a connector. Refer to the latest editions of the National Fuel Gas Code NFPA 54/ ANSI Z223.1 (in the USA) and the Canada National Standard of Canada, CAN/CSA B149.1 and CAN/CSA B142.2 (in Canada).

CFM & TEMPERATURE RISE VS. EXTERNAL STATIC PRESSURE															
MODEL	MOTOR SPEED	TONS AC ¹	EXTERNAL STATIC PRESSURE, (INCHES WATER COLUMN)												
			0.1		0.2		0.3		0.4		0.5		0.6	0.7	0.8
			CFM	RISE	CFM	RISE	CFM	RISE	CFM	RISE	CFM	RISE	CFM	CFM	CFM
DM80SS 0403A*A	High	3	1,521	---	1,466	---	1,414	---	1,373	---	1,298	---	1,243	1,164	1,075
	Med	2.5	1,160	26	1,160	26	1,132	26	1,121	26	1,082	27	1,042	997	925
	Med-Lo	2	961	31	955	31	948	31	932	32	913	33	882	821	803
	Low	1.5	781	38	785	38	781	38	773	38	761	32	745	716	668
DM80SS 0603A*A	High	3	1,422	31	1,352	33	1,307	34	1,197	37	1,157	38	1,092	1,075	983
	Med	2.5	1,098	40	1,081	41	1,051	42	1,039	43	1,021	44	983	924	868
	Med-Lo	2	919	48	913	49	892	50	847	---	829	---	818	792	728
	Low	1.5	758	---	741	---	741	---	733	---	699	---	677	649	626
DM80SS 0604B*A	High	4	2,134	21	2,100	21	2,042	22	1,975	23	1,883	24	1,786	1,700	1,601
	Med	3.5	1,668	27	1,663	27	1,656	27	1,645	27	1,616	28	1,549	1,492	1,391
	Med-Lo	3	1,419	31	1,426	31	1,426	31	1,432	31	1,419	31	1,378	1,328	1,261
	Low	2.5	1,134	39	1,145	39	1,166	38	1,171	38	1,160	38	1,144	1,111	1,071
DM80SS 0804B*A	High	4	2,051	---	1,983	---	1,895	---	1,812	---	1,725	---	1,627	1,530	1,439
	Med	3.5	1,736	---	1,708	35	1,652	36	1,611	37	1,540	38	1,475	1,394	1,307
	Med-Lo	3	1,493	35	1,668	36	1,459	41	1,429	41	1,389	43	1,339	1,274	1,204
	Low	2.5	1,200	49	1,185	50	1,180	50	1,173	51	1,158	51	1,125	1,125	1,080
DM80SS 0805C*A	High	5	2,290	---	2,229	---	2,155	---	2,047	---	1,960	---	1,837	1,712	1,584
	Med	4	1,852	---	1,820	---	1,777	---	1,719	---	1,641	36	1,567	1,469	1,382
	Med-Lo	3.5	1,615	37	1,592	37	1,556	38	1,516	39	1,470	40	1,405	1,346	1,235
	Low	3	1,290	46	1,285	46	1,265	47	1,235	48	1,214	49	1,174	1,044	904
DM80SS 1005C*A	High	5	2,323	---	2,225	---	2,120	35	2,040	36	1,974	38	1,801	1,688	1,577
	Med	4	1,858	40	1,847	40	1,799	41	1,744	42	1,674	44	1,577	1,493	1,399
	Med-Lo	3.5	1,596	46	1,587	47	1,571	47	1,552	48	1,493	50	1,397	1,326	1,217
	Low	3	1,291	57	1,272	58	1,261	59	1,257	59	1,205	61	1,168	1,118	1,060
DM80SS 1205D*A	High	5	2,469	---	2,389	---	2,300	---	2,223	40	2,131	42	2,027	1,902	1,786
	Med	4	1,575	56	1,558	57	1,545	58	1,513	59	1,500	59	1,419	1,354	1,271
	Med-Lo	3.5	1,402	63	1,380	64	1,343	66	1,319	67	1,296	69	1,245	1,183	1,106
	Low	3	1,200	---	1,186	---	1,161	---	1,127	---	1,082	---	1,042	995	926
DM80SS 1405D*A	High	5	2,469	42	2,389	43	2,300	45	2,223	47	2,131	49	2,027	1,902	1,786
	Med	4	1,575	66	1,558	67	1,545	67	1,513	69	1,500	69	1,419	1,354	1,271
	Med-Lo	3.5	1,402	---	1,380	---	1,343	---	1,319	---	1,296	---	1,245	1,183	1,106
	Low	3	1,200	---	1,186	---	1,161	---	1,127	---	1,082	---	1,042	995	926

¹ at 0.5" ESP

NOTES

- CFM in chart is without filter(s). Filters do not ship with this furnace, but must be provided by the installer. If the furnace requires two return filters, this chart assumes both filters are installed.
- All furnaces ship as high-speed cooling and medium-speed heating. Installer must adjust blower cooling and heating speed as needed.
- For most jobs, about 400 CFM per ton when cooling is desirable.
- INSTALLATION IS TO BE ADJUSTED TO OBTAIN TEMPERATURE RISE WITHIN THE RANGE SPECIFIED ON THE RATING PLATE.
- This chart is for information only. For satisfactory operation, external static pressure must not exceed value shown on the rating plate.
- The dashed (---) areas indicate a temperature rise not recommended for this model.
- At higher altitudes, a properly derated unit will have approximately the same temperature rise at a particular CFM, while ESP at the CFM will be lower.

CFM & TEMPERATURE RISE VS. EXTERNAL STATIC PRESSURE															
MODEL	MOTOR SPEED	TONS AC ¹	EXTERNAL STATIC PRESSURE, (INCHES WATER COLUMN)												
			0.1		0.2		0.3		0.4		0.5		0.6	0.7	0.8
			CFM	RISE	CFM	RISE	CFM	RISE	CFM	RISE	CFM	RISE	CFM	CFM	CFM
DD80SS 0403A*A	High	3.0	1,353	---	1,290	---	1,246	---	1,199	25	1,149	26	1,116	1,116	1,099
	Med	2.5	1,183	25	1,113	27	1,098	27	1,052	28	1,039	29	1,006	1,012	969
	Med-Lo	2.0	980	30	946	31	920	32	900	33	896	33	885	855	804
	Low	1.5	778	38	762	39	738	40	746	40	738	40	717	696	678
DD80SS 0603A*A	High	3.0	1,290	34	1,236	36	1,194	37	1,166	38	1,176	38	1,166	1,108	1,029
	Med	2.5	1,139	39	1,090	41	1,035	43	1,063	42	1,063	42	1,020	962	895
	Med-Lo	2.0	962	46	927	48	925	48	941	47	909	49	877	834	779
	Low	1.5	787	56	776	57	763	58	744	60	723	---	690	641	581
DD80SS 0804B*A	High	4.0	2,128	---	2,063	---	2,001	---	1,927	---	1,824	---	1,726	1,628	1,529
	Med	3.5	1,840	---	1,788	---	1,745	---	1,689	35	1,625	36	1,550	1,470	1,364
	Med-Lo	3.0	1,602	37	1,558	38	1,543	38	1,493	40	1,455	41	1,402	1,328	1,239
	Low	2.5	1,277	46	1,252	47	1,244	48	1,229	48	1,214	49	1,179	1,141	1,079
DD80SS 1005C*A	High	5.0	2,405	---	2,361	---	2,250	---	2,161	---	2,037	36	1,937	1,808	1,689
	Med	4.0	1,880	39	1,838	40	1,794	41	1,734	43	1,677	44	1,568	1,510	1,401
	Med-Lo	3.5	1,659	45	1,630	45	1,587	47	1,537	48	1,492	50	1,445	1,368	1,287
	Low	3.0	1,472	50	1,454	51	1,404	53	1,366	54	1,326	56	1300	1228	1139

¹ at 0.5" ESP

NOTES

- CFM in chart is without filter(s). Filters do not ship with this furnace, but must be provided by the installer. If the furnace requires two return filters, this chart assumes both filters are installed.
- All furnaces ship as high-speed cooling and medium-speed heating. Installer must adjust blower cooling and heating speed as needed.
- For most jobs, about 400 CFM per ton when cooling is desirable.
- INSTALLATION IS TO BE ADJUSTED TO OBTAIN TEMPERATURE RISE WITHIN THE RANGE SPECIFIED ON THE RATING PLATE.
- This chart is for information only. For satisfactory operation, external static pressure must not exceed value shown on the rating plate.
- The dashed (---) areas indicate a temperature rise not recommended for this model.
- At higher altitudes, a properly derated unit will have approximately the same temperature rise at a particular CFM, while ESP at the CFM will be lower.

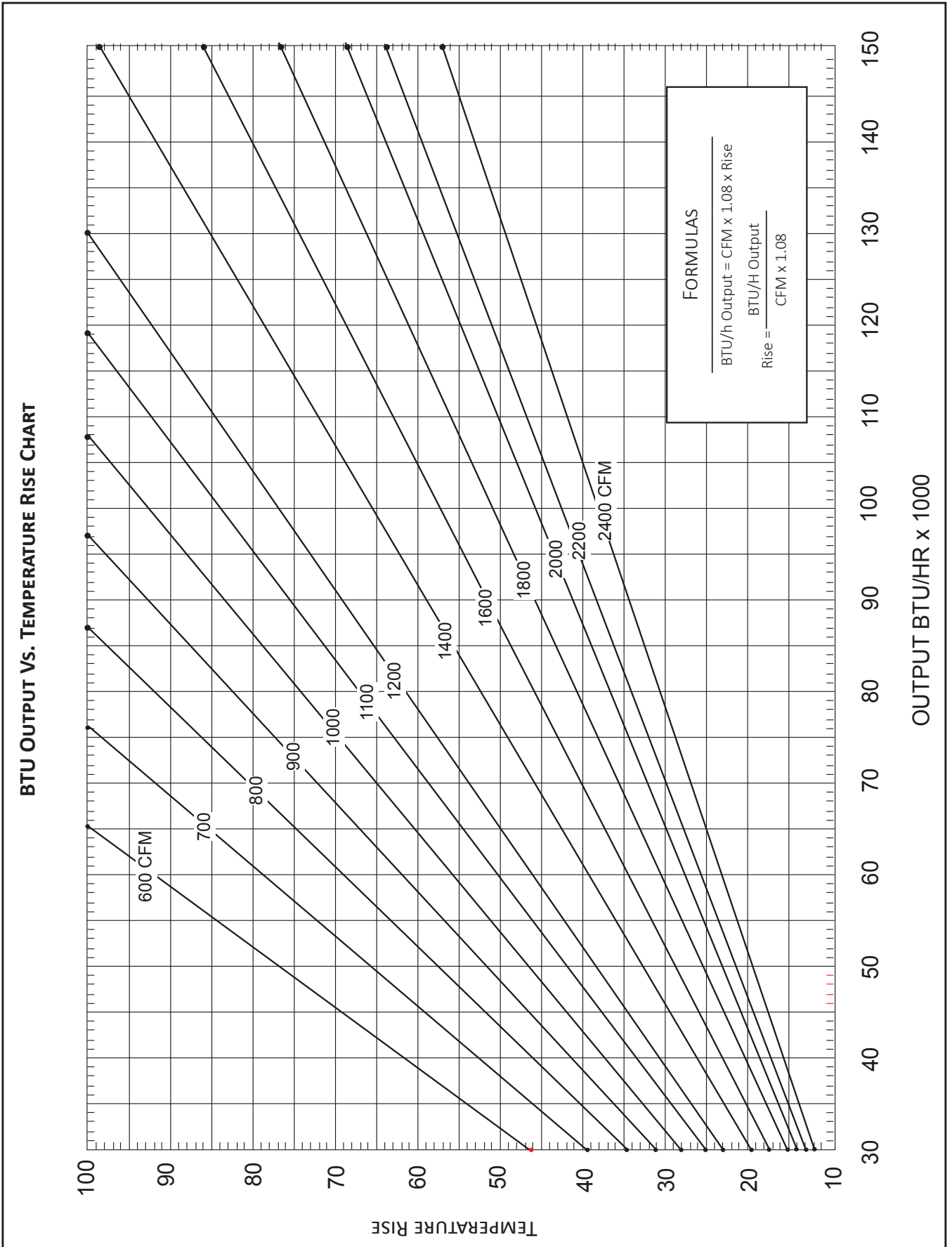

WIRING DIAGRAM

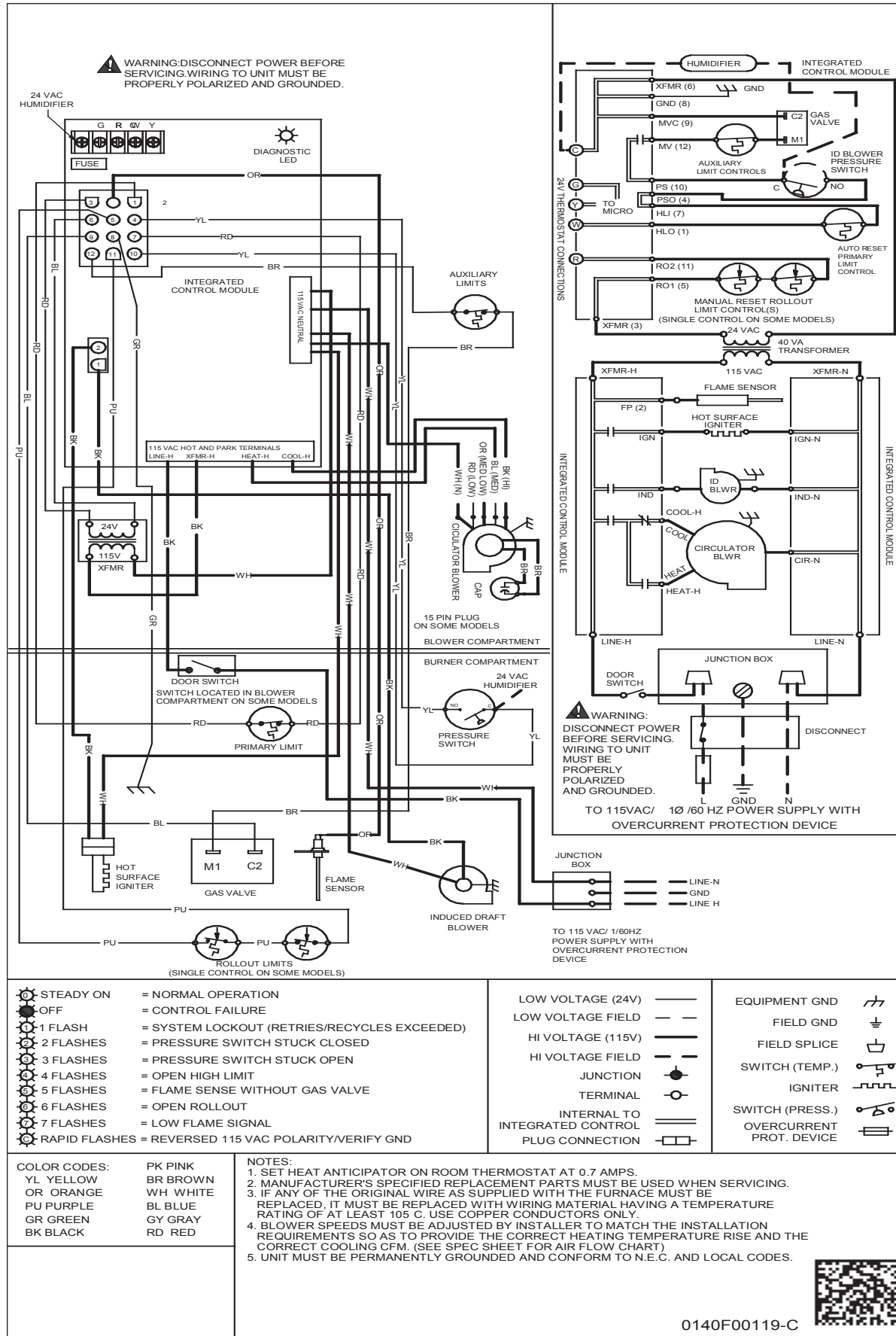

MODEL	DESCRIPTION
LPT-03 ¹	LP Conversion Kit
HANG21	High-Altitude Natural Gas Kit (5500+ ft)
AFE18-60A	Fossil Fuel Kit
MVK-01 ²	Masonry Vent Kit
MVK-02 ²	Masonry Vent Kit (for DM80SS1205D and DM80SS1405D models only)
TK-400	Twinning Kit

¹ White-Rodgers and Honeywell valves

² Upflow applications only

DOWNFLOW SUB-BASE FOR:

MODEL	DESCRIPTION	DD80SS 00403A*A	DD80SS 00603A*A	DD80SS 00804B*A	DD80SS 01005C*A
SBT14	14" Furnace	√	√	---	---
SBT17	17½" Furnace	---	---	√	---
SBT21	21" Furnace	---	---	---	√

DM80SS MINIMUM FILTER SIZES

MODEL #	DM80SS 0403A*	DM80SS 0603A*	DM80SS 0604B*	DM80SS 0804B*	DM80SS 0805C*	DM80SS 1005C*	DM80SS 1205D*	DM80SS 1405D*
Filter Size (in ²)	(1) 16 x 25 (Side) or (1) 14 x 24 (Bottom)		(1) 16 x 25 (Side or Bottom)		(1) 16 x 25 (Side or Bottom) ¹	(2) 16 x 25 (Side) or (1) 20 x 25 (Bottom)	(2) 16 x 25 (Side) or (1) 24 x 24 (Bottom)	

¹ Use 2 - 16 x 25 filters on side returns or 1 - 20 x 25 filter on bottom return if furnace is connected to a cooling unit over 4 tons nominal capacity.

Note: Other size filters of equal or greater surface area may be used; filters may also be centrally located.

DD80SS MINIMUM FILTER SIZES

MODEL #	DD80SS 0403A*	DD80SS 0603A*	DD80SS 0804B*	DD80SS 1005C*
Filter Size (in ²)	(2) 10 x 20 or (1) 14 x 25 (Top Return)		(2) 14 x 20 or (1) 16 x 25 (Top Return)	(2) 14 x 20 or (1) 20 x 25 (Top Return)

Note: Other size filters of equal or greater surface area may be used; filters may also be centrally located.

